

Arcing devices

General	102
Material	104
Upper arcing horn for disc insulators, single	107
Lower arcing horn for disc insulators, sin	107
Upper arcing horn for disc insulators, double	108
Lower arcing horn for disc insulators, double	108
Upper single path arcing ring for disc insulators	109
Lower single path arcing ring for disc insulators	109
Lower single path arcing ring for disc insulators, with ball	110
Lower single path arcing ring for disc insulators, tube material, with ball	110
Single path arcing ring for longrod insulators	111
Single path arcing ring for longrod insulators, with ball	111
Single path intermediate arcing ring for longrod insulators	112
Lower single path arcing ring for longrod insulators, tube material, with ball	112
Grading ring for composite insulators, tube material, with clamp fixing	113
Fork type arcing ring for longrod insulators	113
Fork type intermediate arcing ring for longrod insulators	114
Fork type arcing ring for longrod insulators, with ball	114
Fork type arcing ring for longrod and composite insulators, tube material, with ball	115
Bundles arcing ring for composite insulators	115
Single arcing ring racket type tube material	116
Double arcing ring racket type tube material	116
Single arcing ring racket type solid material	117
Double arcing ring racket type solid material	117

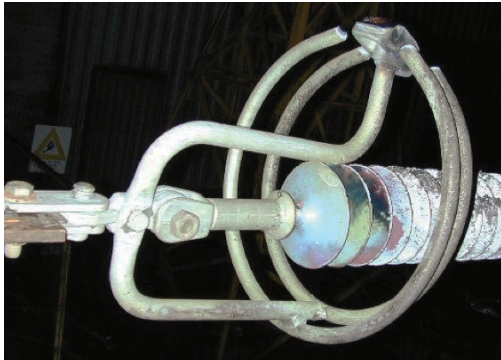

Bundle ring with a composite insulator after a rollover test

General

Arcing devices must fulfil two functions:

- **Even distribution** of the electrical field along the insulator string, suppressing partial discharges and corona effects. To achieve this control, the design, shape, size and positioning are optimised to shield tension and suspension clamps. For higher levels of electrical stress control, special corona rings guarantee suppression within required limits.
- **Protecting the insulator from the effects of a power arc** requires that the device must absorb the full effect of the power arc, acting as a sacrificial component to avoid insulator damage. The device design takes and controls an instantaneous high energy power arc flashover, that has sacrificial parts specifically positioned that may partially burn away to protect the insulator. These events may be triggered by insulator pollution during overvoltage surges.

Once the arcing device has collected the root of the arc, the fitting passes energy between the sacrificial burning points instantaneously. The position relative to the insulator is important, and must be large enough to protect the insulator from the extreme high temperature and radiated heat.

To ensure the burn flash over point stabilises the arc to burn one point, the power must be fed unidirectionally, and allow electromagnetic forces to act upon the power arc. Where replacement of arcing devices become necessary, open rings will allow easy installation, and create migration to the intended burn point. Design of the open ring ends must also avoid corona discharge.

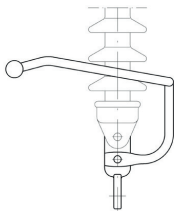

Lower one-way arcing ring with a long rod insulator

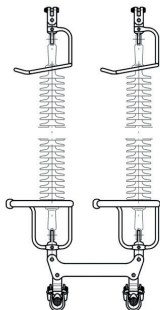

Arrangement of arcing devices in case of a double suspension string

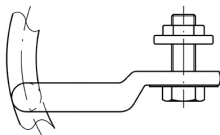

Arcing device for big displacement angles

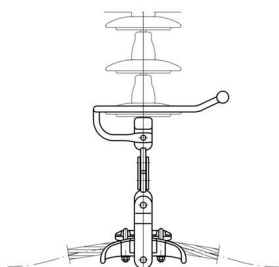

Arcing device for an arrangement in conductor direction

The installation arrangement of arcing devices

The installation of arcing devices will always need adaption to meet performance requirements. The tower support structure and shape, including the insulator string design affects the design of the installation. Where the design is correct, power arc direction will avoid the insulator. Where the power arc direction close to the conductor is unavoidable, special attention needs to be made regarding the design of the end fittings. This ensures that power arc energy is directed away from the conductors, avoiding possible conductor damage.

Arcing devices must not restrict insulator string movement or articulation caused by normal wind energy movement. If necessary, connecting arms are shaped to provide necessary clearances, and ensure that arc gaps are maintained during normal wind induced movement.

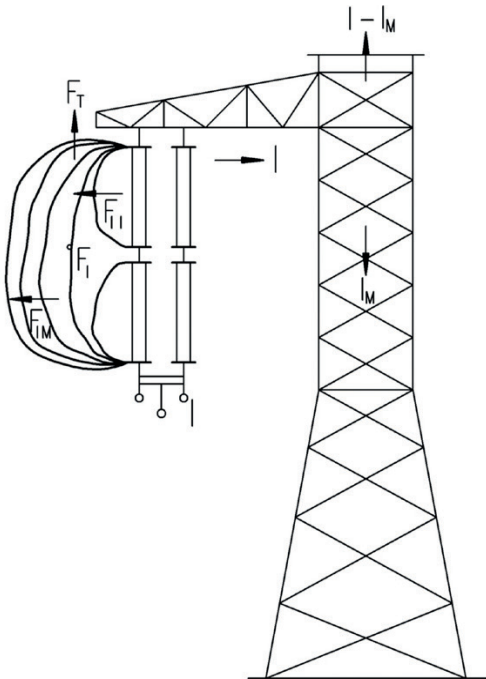

Cascaded power arcs are united to one overall power arc

Short circuit capability

Short circuit capability of arcing devices depends on the cross section through which the current flows.

As arcing devices are not mechanically loaded, a power density of 80 A/mm² is required. This value guarantees a temperature rise is limited to 490°C, as accepted by German DIN requirements. Intermediate arcing rings for long rod insulators can be made smaller, as the initial power surge will be combined for short durations. The materials used for fork type arcing rings can also be smaller, as the stress is shared by two half pieces.

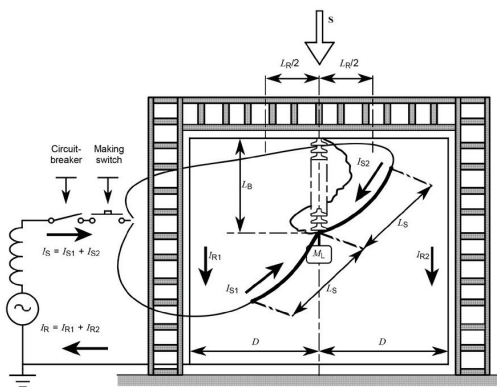

Excerpt from IEC 61467 inspection and testing for insulator strings

Standards

Test qualification of corona resistance acc. to *EN 61284* (Overhead lines - Requirements and tests for fittings) including power arc test requirements acc. to *IEC 61467* (Insulators for overhead lines - Insulator strings and sets for lines with a nominal voltage greater than 1000 V - AC power arc tests) are both made on complete insulator strings.

The values required for corona extinction voltage are partly standardized in national Standards. Test configurations are described in *EN 61284*, where results can be verified.

Testing arrangements, including system calibration, test current, number and duration of short circuit currents, are all described in *IEC 61467*.

Connection interface dimensions for arcing devices are made acc. to *DIN 48068* (Protective fitting attachment; for overhead lines, connection dimensions)

For 24 mm ball fittings, arcing devices are fixed with 2 screws M14 at 32 mm centres, to withstand short circuit currents that may occur.

Double screw fixing are also possible acc. to **Swiss and Italian Standards** (see Part [string hardware](#) of the catalogue).

Arcing devices of the “racket” type will be fixed to the yokes by using two screws M 14 at 60 mm centres.

Corona rings are fixed individually depending on possibilities within the string design.

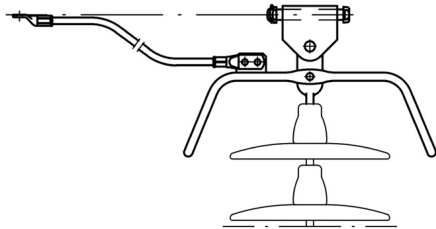

Shunt connection for high short circuit currents

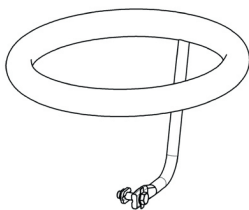

Closed arcing ring

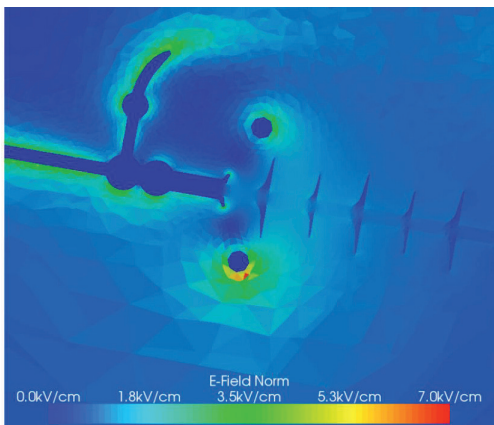

Example for a computation of fields (Lapp Insulators)

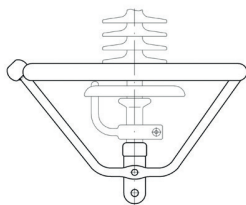

Corona ring and arcing device

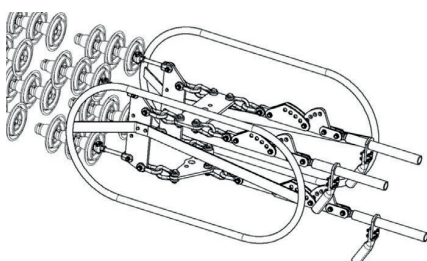

Tension string with arcing rings

Material

- Unless otherwise specified, all ferrous components are hot dipped galvanized acc. to *EN 61284* or *ISO EN 1461*; Overhead lines-requirements and tests for fittings. Where stainless steel fasteners are used, *ISO EN 3506*; Mechanical properties of corrosion resistant stainless steel fasteners - Part 1: Bolts, screws and studs are specified.

Sämtliche Armaturen aus Stahl, sofern sie nicht rostfrei sind, werden feuerverzinkt gemäß *EN 61284* bzw. *ISO EN 1461* - Muttern nach *ISO EN 5306*.

- **For lines constructed in higher corrosive atmospheres and environments, the minimum zinc thickness of fittings can be increased from 85 µm to 110 µm or 130 µm Microns.**
- All fitting assemblies supplied have **identification marking** according to *EN 61284*; this includes manufactures mark, date code and 1 second short circuit current withstand rating.

Where short circuit currents are very high, it is possible to provide a power by-pass using a shunt. Connection facilities are provided at the attachment points.

Closed arcing rings

For compact lines, distances are smaller which can lead to corona discharge problems.

During short circuit events, nowadays transmission lines will be switched out rapidly. Therefore the effects of power arc faults will be limited. This creates the possibility to use closed rings, and provide increased corona voltage extinction performance.

Composite insulators normally require a corona ring on both ends in order to avoid electrical field stress at the material transition points of the end fittings.

This also helps to prevent occurrence of partial discharges and corona phenomena, which can lead to insulating material degradation of the composite insulators.

In many cases, it is useful to install an arcing ring in addition to the corona ring, as corona rings generally do not support arcing protection requirements.

The corona ring will be connected to the insulator on the end fitting by a suitable clamping device.

Closed rings are also used as corona rings for shielding suspension clamps and tension clamps on case of ultra-high-voltage lines.

The designs of the rings are dependent on the system voltage and performance requirements, and are adapted to meet specific requirements.

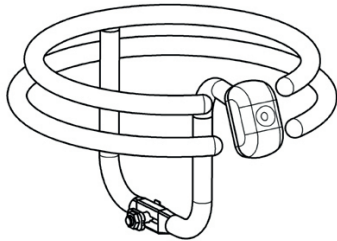

Bundle ring

Bundle rings

The material used to manufacture the bundle ring guarantees rapid transmission of short circuit current, with excellent corona behaviour. These rings can also be used on composite insulated cross arms, where they reduce electrical field stress, and act as arcing device protection.

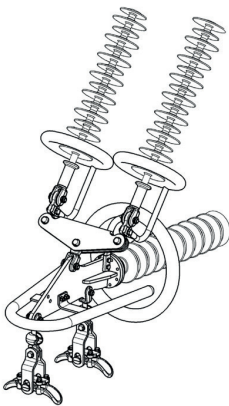

Arcing ring for insulated crossarms

Arcing rings for insulated crossarms

Insulated cross arms are used for compact lines, and made up of many different types of insulating materials, or combinations of glass, ceramic and composite insulators. The tensile insulators often consist of two parallel strings combined with one compression load bearing insulator, where the cross arm is made of porcelain or composite materials. For these applications, specific designs of combined arcing devices and corona rings are required.

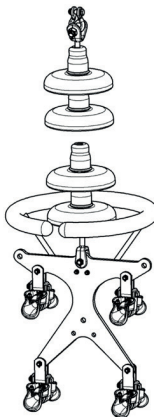

Arcing rings for UHV lines

Arcing rings for UHV (ultra-high voltage) and DC (direct current) lines

For very high voltages and DC lines >500kV, arcing devices listed in the tables may not be suitable in terms of corona resistance. These arcing devices utilise tube diameter ≤ 60 mm. For all other parts, larger fittings for very high voltages and mechanical loadings will be required.

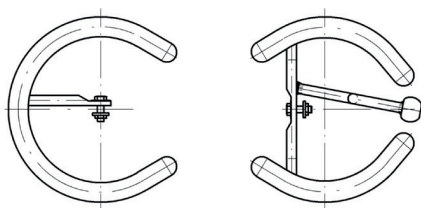

Combination of arcing rings for double suspension strings

Combinations of arcing rings

For double and triple strings sets, live string distances should be as small as possible for safety reasons. Arcing devices should have burn points as far as possible away from the insulators, where it is sometimes not practical to utilise two identical arcing devices. For long rod porcelain insulators, it is also important to ensure arcing rings cannot cause damage to remaining support strings, where load transposition failure has occurred.

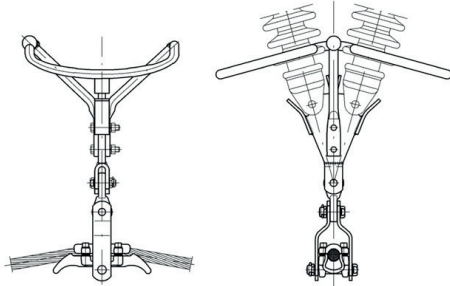

Arcing rings for rigid V-strings

Arcing rings for rigid V-strings

The end of rigid V-strings will be connected to yoke plates at the live side, with a single arcing device attached. This will act to protect both insulator strings, and should be designed according to the one-way principle, of leading the power arc away from the insulator.

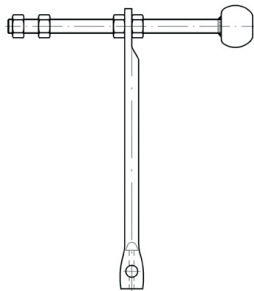

Adjustable protective horn

Adjustable arcing devices

In order to protect the equipment of substations, nominal gaps can be adjusted on the towers close to the substation. This is achieved by use of adjusting arcing devices that can provide arc gap adjustment. Double insulator strings only require arcing protection devices attaching to one string.

For longer insulators, for example in polluted environments, arcing devices are available to offer the correct level of protection for all insulation creepage length requirements.

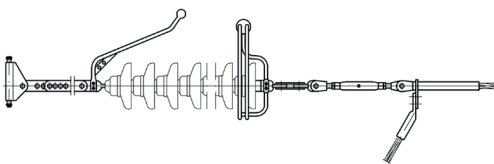

Tension string with cap and pin type insulators with long arcing devices

Corona rings for supporting insulators and devices

Open and closed aluminium rings for shielding in different tube thicknesses and ring diameters are available.

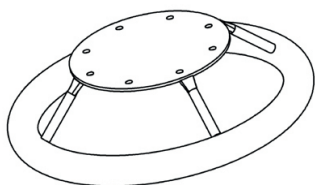

Corona ring for post insulators

Upper arcing horn for disc insulators, single



material: steel, hot dip galvanized

L.-Nr.	A (mm)	B (mm)	C (mm)	kA 1s	kg
4726.05	190	250	16	16	0,75
4726.22	190	250	20	25	1,05
4726.14/4	190	250	22	30	1,30
4710.20	210	250	25	40	1,70

Other types are available upon request.

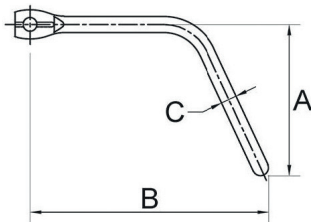

Lower arcing horn for disc insulators, sin



material: steel, hot dip galvanized

L.-Nr.	A (mm)	B (mm)	C (mm)	kA 1s	kg
4726.06	105	250	16	16	0,70
4726.20	105	250	20	25	0,94

Other types are available upon request.

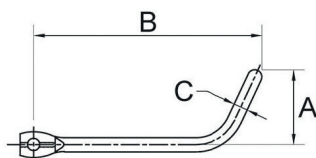

Upper arcing horn for disc insulators, double



material: steel, hot dip galvanized

L.-Nr.	A (mm)	B (mm)	C (mm)	kA 1s	kg
4725.05	200	500	16	16	1,13
4725.0010	190	500	22	30	2,20
4725.0028	190	500	25	40	2,70

Other types are available upon request.

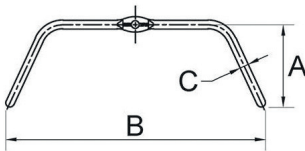

Lower arcing horn for disc insulators, double



material: steel, hot dip galvanized

L.-Nr.	A (mm)	B (mm)	C (mm)	kA 1s	kg
4725.06	105	500	16	16	1,07
4725.25	105	500	20	25	1,58

Other types are available upon request.

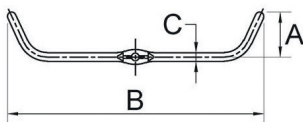

Upper single path arcing ring for disc insulators



material: steel, hot dip galvanized

L.-Nr.	A (mm)	B (mm)	C (mm)	D (mm)	kA 1s	kg
4760.01	185	451	16	330	16	2,30
4760.02	185	455	20	330	25	3,70
4760.03	185	457	22	330	30	4,60
4760.04	185	459	24	330	35	5,32
4760.04/2	185	463	28	330	50	7,05

Suitable for disc insulators with a diameter up to 280 mm.
Bigger diameters are available upon request.
Other types are available upon request.

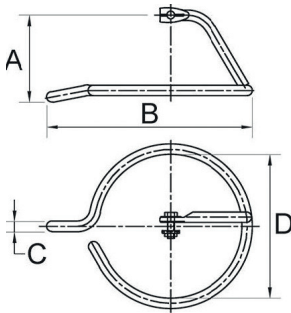

Lower single path arcing ring for disc insulators

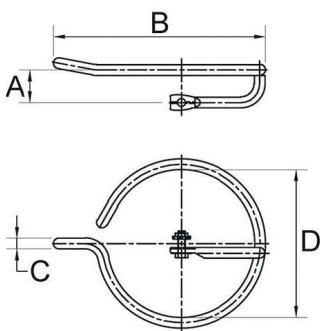

material: steel, hot dip galvanized

L.-Nr.	A (mm)	B (mm)	C (mm)	D (mm)	kA 1s	kg
4760.22	100	455	20	330	25	3,65
4760.23	100	457	22	330	30	4,43
4760.24	100	475	24	330	35	4,95
4760.24/1	100	475	28	330	50	6,85

Suitable for disc insulators with a diameter up to 280 mm.
Bigger diameters are available upon request.
Suitable for nominal voltages of up to 110 kV.
Other types are available upon request.

Lower single path arcing ring for disc insulators, with ball



material: steel, hot dip galvanized

L.-Nr.	A (mm)	B (mm)	C (mm)	D (mm)	E (mm)	kA 1s	kg
4760.32	100	455	20	330	40	25	3,80
4760.34	100	459	24	330	40	35	6,50
4760.0001	100	460	25	330	40	40	5,90

Arcing rings with a diameter of 330 mm can be used for disc insulators with a diameter up to 245 mm. Suitable for nominal voltages up to 220 kV. Other types are available upon request.

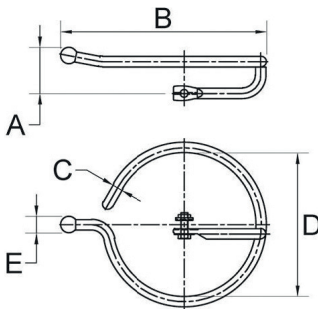

Lower single path arcing ring for disc insulators, tube material, with ball

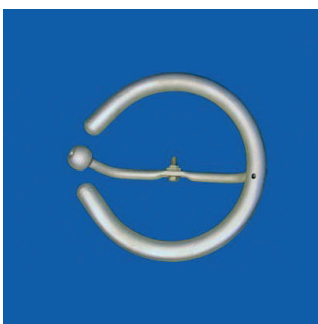

material: steel, hot dip galvanized

L.-Nr.	A (mm)	B (mm)	C (mm)	D (mm)	kA 1s	kg
4770.04	100	354,0	48	60	30	6,47
4770.05/3	100	354,0	48	60	40	6,90
4770.05	100	354,0	48	60	35	7,09
4770.0005	100	453,4	48	60	40	8,90

Arcing rings with a diameter of 350 mm can be used for disc insulators with a diameter up to 245 mm. Other types are available upon request.

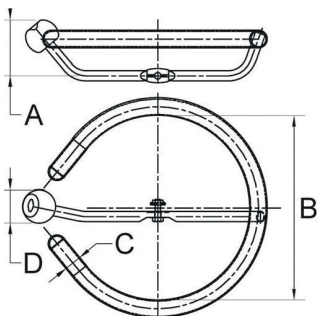

Single path arcing ring for longrod insulators



material: steel, hot dip galvanized

L.-Nr.	A (mm)	B (mm)	C (mm)	D (mm)	kA 1s	kg
4750.10/1	185	340	16	200	16	1,69
4750.19/1	195	340	20	200	25	2,60
4750.17/1	198	410	20	220	25	2,90
4750.13/2	198	410	22	200	30	3,30
4750.18/1/1	198	390	22	220	30	3,50
4750.36	210	450	22	250	30	3,80
4750.45	210	400	25	220	40	4,54
4750.15/6	227	450	28	220	50	6,22
4750.16	350	470	30	260	50	8,35

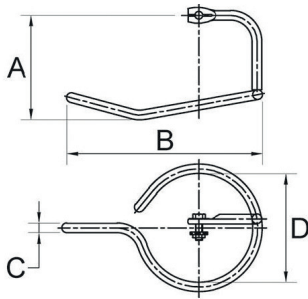

Other types are available upon request.
Arcing rings with 2 bolt attachment on request.

Single path arcing ring for longrod insulators, with ball



material: steel, hot dip galvanized

L.-Nr.	A (mm)	B (mm)	C (mm)	D (mm)	E (mm)	kA 1s	kg
4750.40	227	370	16	200	30	16	2,10
4750.54/86	210	450	20	305	30	25	4,10
4750.32	185	350	22	170	30	30	3,04
4750.43	227	450	22	200	30	30	3,68
4750.49/3	220	400	24	220	40	35	4,50
4750.15/72	165	450	25	280	40	40	5,30
4750.55/5	290	460	28	305	80	50	7,90

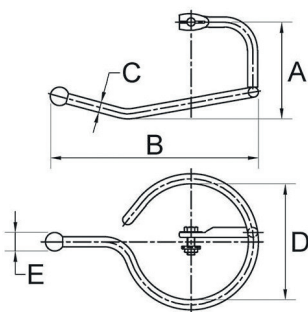

Other types are available upon request.
Arcing rings with 2 bolt attachment on request.

Single path intermediate arcing ring for longrod insulators



material: steel, hot dip galvanized

L.-Nr.	A (mm)	B (mm)	C (mm)	D (mm)	kA 1s	kg
4750.64	420	340	16	200	50	3,50
4750.698	454	460	16	260	50	4,05
4750.752	710	460	16	320	50	4,80
4750.66/2	396	390	22	220	50	6,80

Suitable as a lower arcing device for nominal voltages up to 380 kV.

The one second short circuit current that is stated refers to the fact that current will, in case of short circuit, flow only a short time through the fitting because the power arc will be united over the upper and lower fittings.

Other types are available upon request.

Arcing rings with 2 bolt attachment on request.

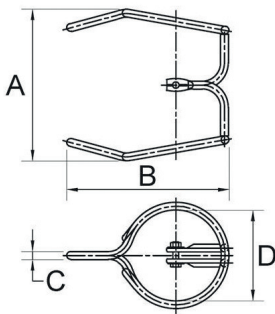

Lower single path arcing ring for longrod insulators, tube material, with ball



material: steel, hot dip galvanized

L.-Nr.	A (mm)	B (mm)	C (mm)	D (mm)	E (mm)	kA 1s	kg
4750.73/2	300	425	48	304	60	40	8,19
4750.72/1	210	460	48	354	60	40	8,70
4750.78/2	215	453	48	354	80	50	9,00
4750.70	235	460	48	354	60	30	7,50
4750.85/3	290	570	48	354	80	50	12,10

For multiple strings, special models can be supplied.

Other types are available upon request.

Arcing rings with 2 bolt attachment on request.

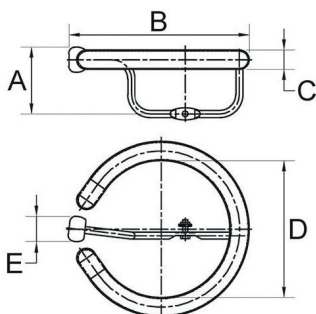

Grading ring for composite insulators, tube material, with clamp fixing



material: aluminium

L.-Nr.	A (mm)	B (mm)	C (mm)	D (mm)	kA 1s	kg
4740.61/1	115	253,4	48,0	31,0	16	4,28
4740.69/A	77	304,0	48,0	46,0 - 49,0	24	2,12
4740.70/1/A	77	324,0	48,0	46,0	16	2,24

Other types are available upon request.

Arcing rings with 2 bolt attachment on request.

L.-Nr. 4740.61/1 made from steel.

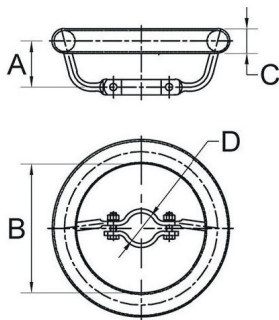

Fork type arcing ring for longrod insulators



material: steel, hot dip galvanized

L.-Nr.	A (mm)	B (mm)	C (mm)	D (mm)	kA 1s	kg
4750.9051	130	320	16	205	25	2,10
4750.9007	165	320	16	205	25	2,16
4750.52/1	165	320	20	205	30	2,95
4750.321	165	320	20	205	40	3,31
4750.52/0	165	320	20	205	40	3,42
4750.52/7/1	210	320	20	205	40	3,60
4750.9852	150	455	20	340	40	4,60

Suitable as a lower arcing device for nominal voltages up to 110 kV.

Other types are available upon request.

Arcing rings with 2 bolt attachment on request.

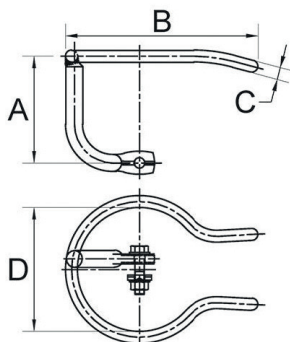

Fork type intermediate arcing ring for longrod insulators



material: steel, hot dip galvanized

L.-Nr.	A (mm)	B (mm)	C (mm)	D (mm)	kA 1s	kg
4750.60/0	330	320	16	205	50	3,88
4750.9005	410	320	16	205	50	4,10
4751.9301	390	360	16	240	50	5,60
4750.52/30	480	395	16	280	50	4,90

Suitable as a lower arcing device for nominal voltages up to 380 kV.

The one second short circuit current that is stated refers to the fact that current will, in case of short circuit, flow only a short time through the fitting because the power arc will be united over the upper and lower fittings.

Other types are available upon request.

Arcing rings with 2 bolt attachment on request.

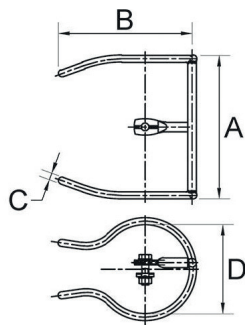

Fork type arcing ring for longrod insulators, with ball

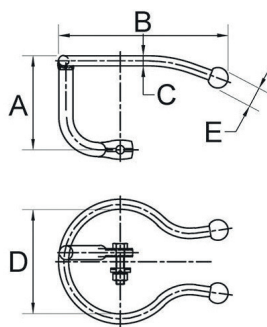

material: steel, hot dip galvanized

L.-Nr.	A (mm)	B (mm)	C (mm)	D (mm)	E (mm)	kA 1s	kg
4750.9857	110	470	16	340	40	25	3,20
4750.52/7/2	165	335	20	205	40	45	4,00
4750.52/2	165	360	20	205	60	40	4,90
4750.52/7/3	225	335	20	205	40	40	4,25
4750.9303	315	375	20	240	40	40	5,00

Other types are available upon request.

Arcing rings with 2 bolt attachment on request.

Fork type arcing ring for longrod and composite insulators, tube material, with ball



material: steel, hot dip galvanized

L.-Nr.	A (mm)	B (mm)	C (mm)	D (mm)	E (mm)	kA 1s	kg
4750.52/24	250	455	48	304	85	50	7,03
4740.9504	240	490	48	344	85	50	7,63
4740.9511	320	490	48	344	85	50	7,80
4750.52/24/3	200	485	51	298	85	40	10,25
4750.52/27	210	545	51	348	85	40	10,20

Other types are available upon request.
Arcing rings with 2 bolt attachment on request.

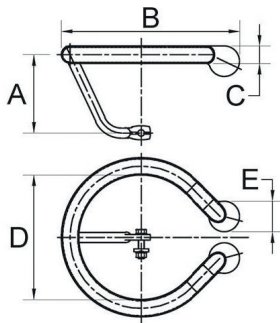

Bundles arcing ring for composite insulators



material: steel, hot dip galvanized

L.-Nr.	A (mm)	B (mm)	C (mm)	D (mm)	kA 1s	kg
4755.06	300	525	24	400	63	17,40
4755.12/5	300	424	25	310	40	15,00
4755.12/4	330	424	25	310	40	15,90
4755.12/6	370	424	25	310	50	15,45
4755.12/1	295	427	28	310	40	15,60

Similar corona rings can also be delivered for disc insulators and long-rod insulators made of porcelain. All corona rings do not only provide excellent corona resistance for nominal voltages of up to 400kV but also by ensuring that the power arc, in case of a short circuit, will travel to the end burning point very rapidly.

Other types are available upon request.
Arcing rings with 2 bolt attachment on request.

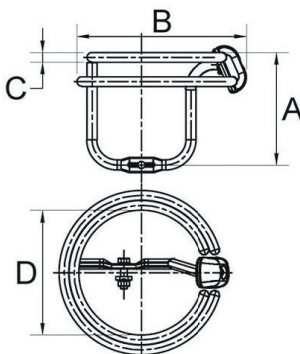

Single arcing ring racket type tube material



material: steel, hot dip galvanized

L.-Nr.	A (mm)	B (mm)	C (mm)	D (mm)	E (mm)	kA 1s	kg
4727.02/13	220	370	38	500	60	40	3,60
4727.04/15	245	450	48	700	60	50	7,00

Other types are available upon request.

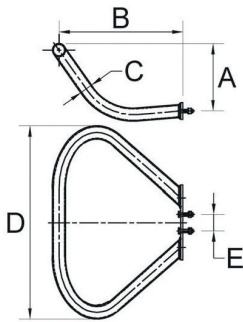

Double arcing ring racket type tube material

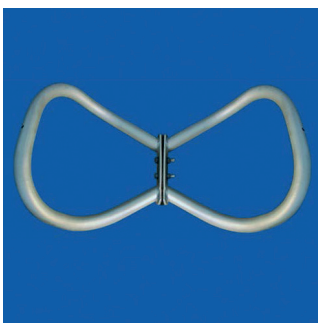

material: steel, hot dip galvanized

L.-Nr.	A (mm)	B (mm)	C (mm)	D (mm)	E (mm)	kA 1s	kg
4727.04/12	245	450	38	600	60	40	8,50
4727.04/11	145	450	48	700	60	50	16,74
4727.02/4	245	450	48	500	60	50	12,50
4727.04/4	245	450	48	700	60	50	14,40

Other types are available upon request.

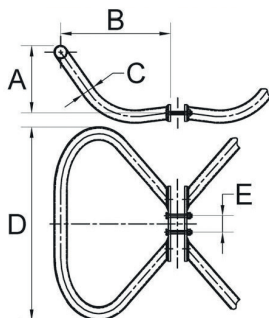

In der Engl. PDF Vorlage war kein Zusatz dabei

Single arcing ring racket type solid material



material: steel, hot dip galvanized

L.-Nr.	A (mm)	B (mm)	C (mm)	D (mm)	E (mm)	kA 1s	kg
4729A09	130	285	20	600	80	32	3,92
4729A10	190	285	20	600	80	32	4,20
4729A05/1	190	290	20	200	-	32	2,80
4729A05	105	300	20	200	-	32	2,20

The L.N. 4729A05 and 05/1 equipped with one bolt for connection according to DIN 48608. Other types are available upon request.

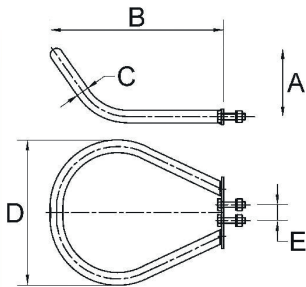

Double arcing ring racket type solid material

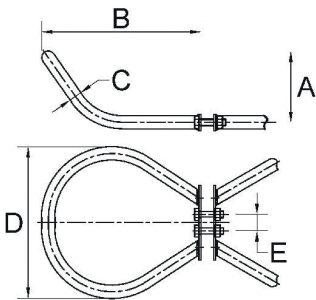

material: steel, hot dip galvanized

L.-Nr.	A (mm)	B (mm)	C (mm)	D (mm)	E (mm)	kA 1s	kg
4729A09/1	130	285	20	600	80	32	7,80
4729A10/1	190	285	20	600	80	32	8,09
4729A06	105	290	20	200	-	32	4,20
4729A06/1	190	290	20	200	-	32	4,75

The L.N. 4729A06 and 06/1 equipped with one bolt for connection according to DIN 48608. Other dimensions and types are available upon request.